

**SIDE ELEVATION**

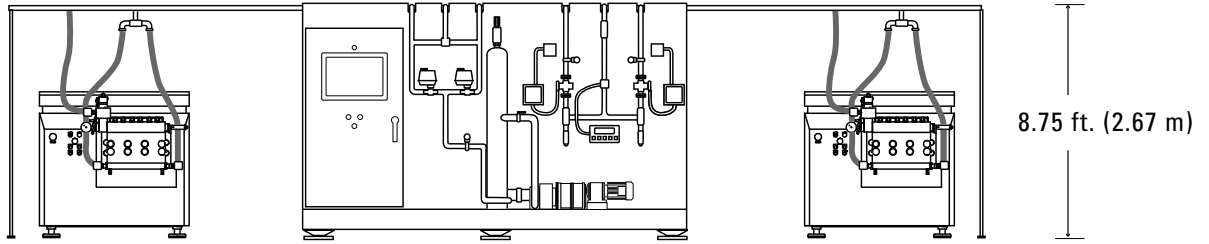

**PLAN VIEW**

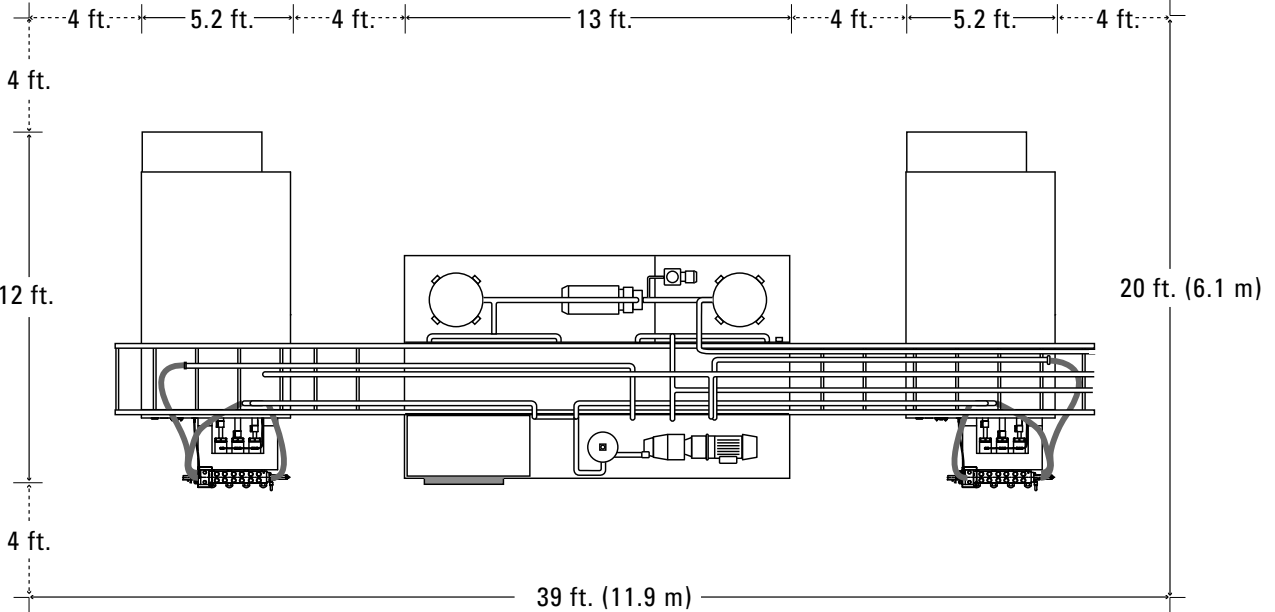

PHYSICAL	Imperial	Metric
Footprint (including service access, but not forklift access)	39 x 20 ft.	11.9 x 6.1 m
Height	8.75 ft.	2.67 m
Weight (empty)	17 tons	15.4 tonnes
Weight (operating)	27 tons	24.5 tonnes
CAPACITY		
TWAS feed flow rate - per day	25,200 gal/day	96 m <sup>3</sup> /day
- per hour	1,050 gal/hour	4 m <sup>3</sup> /hour
- per minute	17.5 gal/min	66.7 L/min
TWAS FEED		
TWAS feed concentration	up to 8% TS	
TWAS feed pressure	40 psi (15 psi > outlet pressure)	3 bar (1 bar > outlet pressure)
TWAS outlet pressure (site dependent)	15 - 25 psi	1 - 2 bar
UTILITIES		
Operating environment	39 - 95 °F	4 - 35 °C
Compressed air (intermittent use, dry and oil free)	90 psi @ 10 ft <sup>3</sup> /min	6.2 bar @ 283 L/min
Caustic consumption (25 wt%)	75.6 gal/day	286 L/day
Electrical	350 hp 400 Amps @ 460 VAC	
Cooling water flow (free of solids)	2 gal/min	7.6 L/min